

# DIESEL ENGINE FAILURES DUE TO FUEL WITH INSUFFICIENT LUBRICITY

A.J.von Wielligh, N.D.L.Burger, T.L.Wilcocks

Department Of Mechanical And Aeronautical Engineering  
University of Pretoria  
Pretoria 0002 Republic of South Africa

## 1. Abstract

A large number of diesel engine failures have been reported in the immediate past. The large proportion of these engines that were investigated, were recently overhauled engines that failed soon after the overhaul process. In some cases, these engines failed on the dynamometer, while it was tested before delivery to the customer.

The most common failure on a large number of these engines, were pistons seizing in the crown region causing seizure of the piston in the cylinder. When these failures were investigated the problem could be traced back to combustion irregularities.

The injector which was usually newly fitted as a genuine part, became sticky causing poor vapouration of the diesel. The stickiness of the injector tip was found to be due to poor lubricity of the fuel.

Tests were done to correlate the lubricity of the fuel that was used and the failure of the engines. A correlation was found. Limits were obtained from which it could be determined when the fuel was not of a proper quality and where engine failures took place.

It is finally recommended that the specification SABS 342 be amended to include the requirements of lubricity of diesel fuels.

## 2. Introduction

During the regular investigation of engine failures, it was found that a large proportion of engines failed due to the seizing of the piston in the cylinder liner. Very often this happens soon after overhaul. The nature of these failures are that the piston starts seizing on the piston crown and this then gradually works its way down to the skirt of the piston. Several cases were also encountered where the piston crown started melting and in some cases holes were melted through the crown of the piston. Figure 1 and 2, shows the typical type of damage that pistons sustain.



Figure 1: Hole through piston



Figure 2: Melted piston crown

The damage to these pistons are typical of that of a combustion related failure.

In the majority of these cases, the injectors were carefully taken out and tested. When gently pumped on the test rig, the injectors emitted streams of diesel instead of the normal vapour. This means that the injector needles were stuck. A typical test where jets of fuel are delivered, is shown in figure 3.

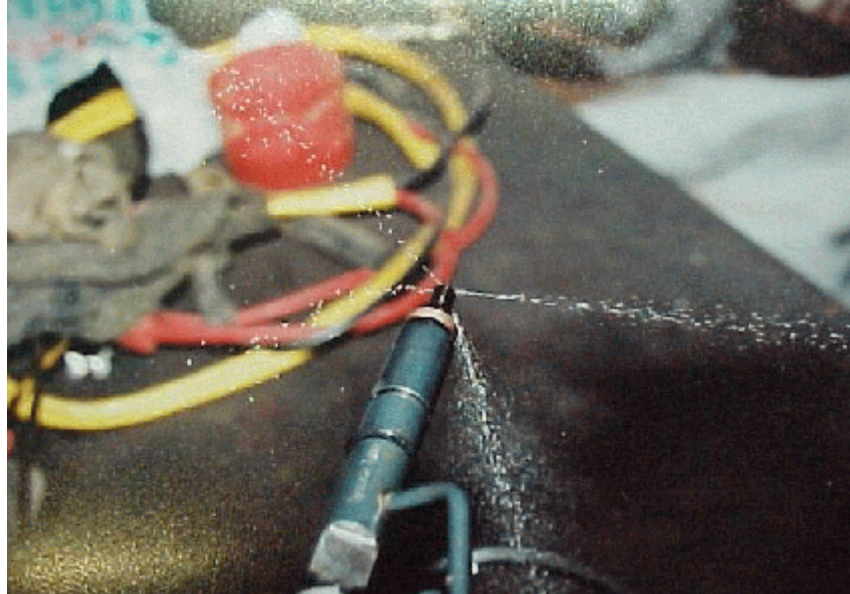

Figure 3: Poor injector spray pattern

When pumped, hard and quickly by hand, the needles tended to loosen up and the spray pattern improved. This led to the problem encountered, that on the failed engines some pump rooms normally commented that the spray pattern of the injectors were not 100% but that they were reasonable. The injectors would then soon afterwards fail again if they were put back into the engine.

When these injectors were stripped, the needle points were discoloured and black and in quite a few cases damage to the shank of the injector needle could be seen under the microscope. Examples of this discolouration and the damage to the shank are shown in figures 4, 5 and 6.

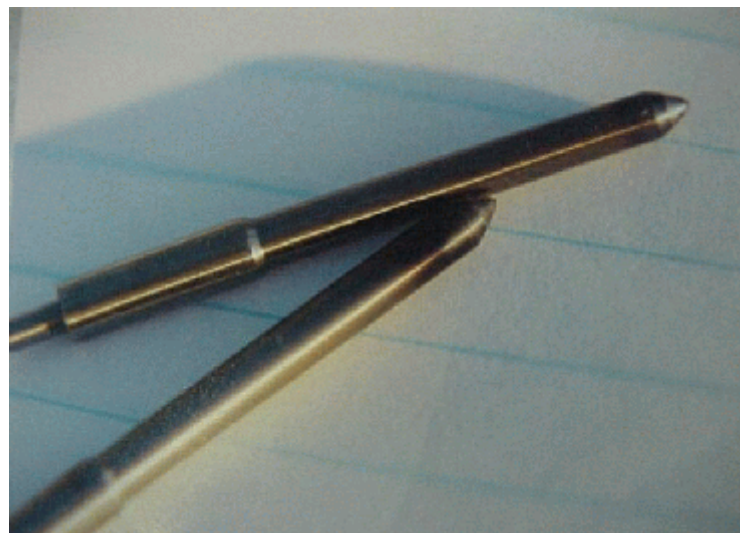

Figure 4: Discolouring of injector needle surface

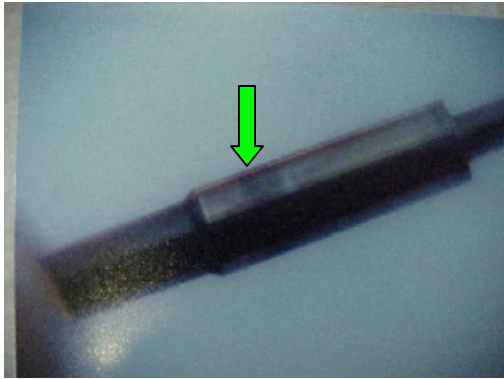

Figure 5: Arrow indicates scratches on needle shank

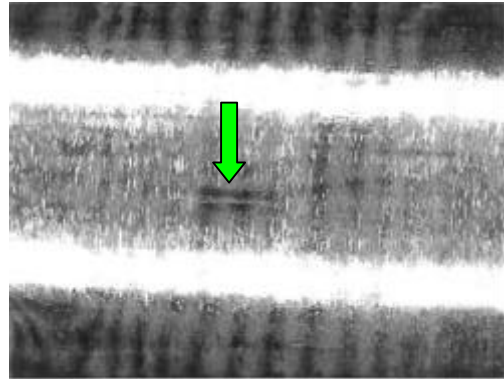

Figure 6: Scratch marks under microscope

The dark or discoloured ends of the needles of the injector are an indication that the needle did not seal properly on the bottom of the injector tip and the combustion gasses were allowed to blow through the orifices, back into the needle chamber causing excessive temperatures and discolouration of the needle tip. The scuffing that could be seen under the microscope is an indication that seizing occurred between the injector needle and the injector tip body. Scuffing is an indication of poor lubrication conditions, as this needle has to be lubricated by the fuel. This is therefore an indication of a fuel lubricity problem.

The existing South African specification for diesel fuel, SABS 342, does not include any requirements for lubricity of diesel fuels but only specifies boiling points, cetane number, viscosity, etc.

An investigation was therefore carried out, regarding the lubricity of fuel found in diesel engines where seizing of pistons occurred, due to combustion irregularities.

### 3. Background

#### 3.1 Diesel engine principles and operation

The piston of a diesel engine fits tightly in the cylinder to provide high compression in order to cause ignition of the injected fuel.

Fuel is delivered in metered quantities to the cylinders, at very high pressures and is broken up in a fine spray with droplets usually smaller than 20 microns. This is done by forcing the fuel through small orifices at very high pressures.

In the hot air caused by compression, the fuel starts burning and due to the heat released, the pressure rises and the piston is forced down, to produce the power of the engine. It must be kept in mind that the injection is not an instantaneous happening. The injection process starts between 25° and 10° before Top Dead Centre and continues while combustion takes place and the piston starts moving downwards. The power output of the engine is controlled by the amount of fuel injected, which in turn is controlled by the duration of the injection process.

### 3.2 Spray pattern requirements

The injected fuel is broken up in a very fine spray and the combustion process starts by oxidizing the fuel droplets from the surface of these drops. It must furthermore be kept in mind that the smaller the droplets, the bigger the specific area, which means that combustion takes place faster and more efficiently. There is therefore a tendency towards smaller droplets and finer spray in the higher pressure modern diesel engines. The spray is obtained by supplying fuel to the needle which is in the closed position and held down by a spring. When the pressure has built up sufficiently, the spring force is overcome and the needle is lifted from the seat. At this point in time a very high pressure exists around the needle. This high pressure then forces diesel through the orifices of the injector tip and a very fine spray is obtained. The layout of an injector is shown in figure 7.

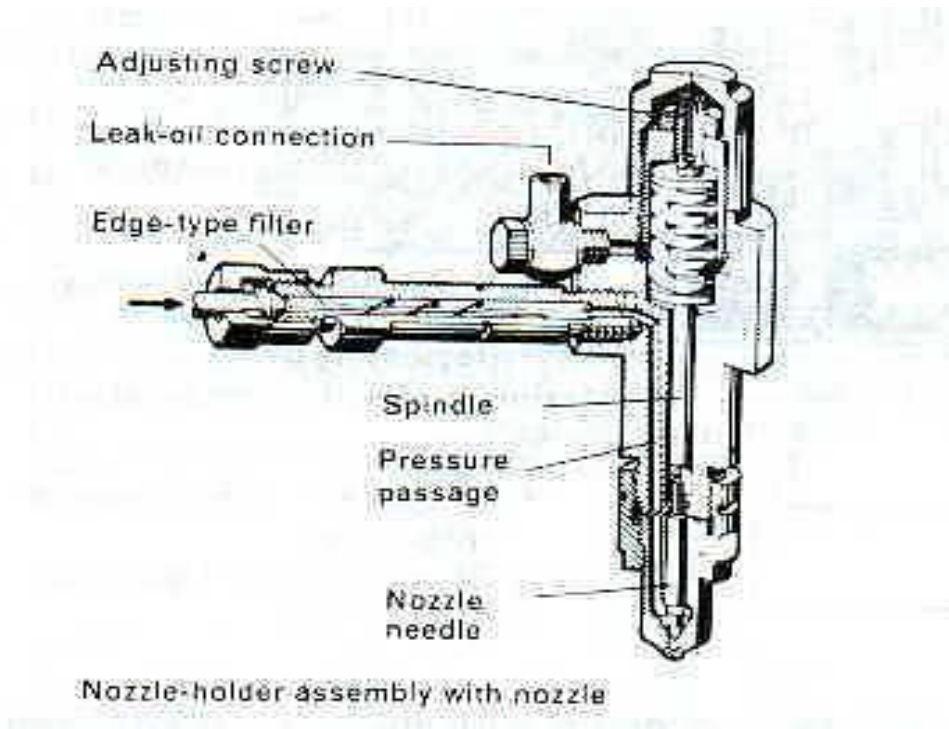

Figure 7: Injector layout

### 3.3 Causes of poor spray patterns

The most important cause of a poor spray pattern, is a low pressure in the injector tip area before injection starts. This low pressure can be caused by amongst others the following reasons:

1. Leaking of the needle on the seat of the injector tip.

When the needle does not seal properly on the seat and fuel is applied, the fuel starts leaking out through the orifices before a high pressure is built up. This causes large droplets and can also cause “dripping” of fuel on the injector tip.

2. Sticking needle

When the needle is not free to move in the injector tip, the spring force is usually insufficient to

properly seal the needle on the seat. When pressure is then applied to the injector tip, leaking starts and usually jets of fuel are emitted from the orifices instead of the normal fine spray.

#### 3.4 Consequences of poor spray pattern.

When a poor spray pattern exists as described above, the following actions usually take place:

##### 1. Washing away of the oil film on the cylinder wall.

When ever a jet of diesel fuel is directed onto the cylinder wall, the thin film of lubricating oil is washed away. This leads to dry rubbing of the piston material and piston ring on the cylinder wall. Due to the absence of the lubricating film, the friction coefficient is higher, excessive heat is developed and seizing occurs. In some cases accelerated wear can also take place.

##### 2. Melting of the piston crown material

When ever jets of fuel or drops of fuel fall onto the piston crown it starts burning on the material of the piston and overheats this material. In the case of aluminium pistons, the melting temperature of aluminium is soon reached and the material is blown out through the exhaust valve. In severe cases, holes can also be blown through the crown of the piston. Examples of this type of damage is shown in figures 1 and 2.

#### 4. **Lubricity Of Diesel Fuel**

In these days of high fuel prices virtually any fuel that can burn in a compression ignition engine is tried out by some people. It furthermore must be kept in mind that the fuel as it is manufactured at the refineries, does not necessarily have enough inherent lubricity. This is especially the case in the lighter fractions of diesel or Kerosene. In order to make these fuels acceptable for use in diesel engines, additives are normally added by the fuel companies to make the fuel acceptable for engine operation. It must kept in mind that modern diesel engines run at very high temperatures and at very high loads, encouraging the addition of good lubricity additives.

##### 4.1 The purpose of fuel additives

The base fuel does not necessarily have enough lubricity properties to be able to use this in a diesel engine. Additives are therefore added to provide proper lubrication between moving parts in the injection system. It must be kept in mind that the components of the injection system are operating at high temperatures and high pressures and must be lubricated by the fuel. Due to the very small clearances in diesel injection equipment, the lubrication normally takes place in the elastohydrodynamic range or even the mixed and boundary lubrication regimes. The fuel must therefore be able to prevent sticking of the moving parts.

A careful balance must be maintained in regard to the concentration of additives added because cases have been reported where too much additives were added, which in turn reacted with oil additives from the lubricating system of the engine, causing problems. If the quantity of additives is too small, seizing of the components can occur. The economics of these additives must also be kept in mind, as these additive packages are usually costly.

## 4.2 Typical tests for lubricity

Several tests are presently in use to test particular aspects of lubrication. It is therefore important to determine exactly the conditions under which certain components operate before deciding on a particular lubrication test. The following tests were considered and tried in the investigation into the lubricity of diesel fuels

1. The Timken test machine was modified in such a way that the friction forces could be measured directly and the friction co-efficient determined from the test. This testing method was not pursued for long, because the conditions under which the needle in the injector operates is not really comparable to the conditions of the Timken test unit.
2. The Shell four ball tester in the laboratories of the South African Bureau of Standards, was used to determine the friction coefficient of the diesel fuel. Reasonable results were obtained from these tests, but as the operating conditions of this test method are also not readily comparable to the operation of the injector, these tests were terminated.
3. When a test method for an injector is selected, it must be kept in mind that the injector operates at a reasonably high temperature, usually in the region of 110°C. Furthermore, the injector operates in a linear mode of small amplitude, with the needle moving up and down in the barrel of the injector tip. The clearances are extremely small usually in the order of fractions of a micron. Several other methods like the SLBOCLE (Scuffing Load Ball On Cylinder Evaluator) and the HFRR (High Frequency Reciprocating Rig) were developed. It would seem that the HFRR is gaining preference all over the world for the testing of the lubricity of diesel fuels. Another test method that is used, is the Bosch test where a blue printed pump is run for about 1000 hours and the damage on the pump determined. Due to the non availability of the normal HFRR, and the very high cost of the Bosch test, it was decided to make use of the OPTIMOL RECIPROCATING RIG (SRV) available at the Tribology Laboratory of the University of Pretoria. This machine has a 10 mm steel ball sliding against a 25 mm diameter disc, in an off centre mode. The ball is loaded in increments that are adjustable and the frequency and stroke of the sliding action can also be changed. The friction between the ball and the disc results in a torque being exerted on the disc and this torque is measured. From this torque the friction co-efficient is calculated by a computer. The output from this process is therefore a friction versus load characteristic. The disc and ball are flooded by dripping the diesel fuel onto the contacting surfaces.

## 4.3 Tests done on the SRV machine at the University of Pretoria

After running a large number of tests on fuels that produced failure in engines as well as fuels that did not produce failures, the following parameters were chosen for the evaluation of the fuels:

Stoke	1 mm
Frequency of vibration	50Hz
Operating temperature	110°C
Load	Initial load 50N with an increase of 50N every minute
Break through friction co-efficient	0,3
Minimum load before break through friction co-efficient is obtained	700N

During the tests it was furthermore realized that under initial light load the process showed very erratic results. A second test was therefore run, using similar operating parameters but load increase of only 10N per minute from an initial 50N to determine the initial start-up the action of the machine. These tests were run as separate tests at the varying load conditions. Various samples were tested and it was eventually decided to use diesel oil which was refined from crude oil as a reference. This was done as it was established that vehicles running on this fuel did not exhibit any of the afore mentioned problems.

## 5. Results Of Tests Carried Out And Case Studies

5.1 As mentioned above it was necessary to establish a base line for reference purposes. For this purpose coastal diesel was tested. The result of this test is shown in graph 1 in the Annexure.

As a comparison illuminating paraffin and jet fuel were also tested. The results of these tests are shown graphs 2 and 3 in the Annexure. This was done, because it is known that some diesel distributors are adding kerosene or jet fuel to diesel, to make more profit.

5.2 Several of the South African mines make use of a so called "Underground Diesel", to reduce air pollution of diesel engines in confined spaces. This underground diesel is basically kerosene with a proper additive. From a mine where no problems with sticking diesel injectors are experienced, samples were obtained and these were tested. The results of these tests are shown in graphs 4 and 5 in the annexure. It can be seen that this fuel passes the parameters and limits that were decided upon initially.

5.3 When the failure of a 5 cylinder diesel engine from a vehicle was investigated, it was found that the Bosch injection pump failed due to the fact that the plunger seized and twisted off. Diesel was extracted from the tank of this vehicle and tested. The results of this test are shown in graph 6 in the annexure. As can be seen from the graphs, the fuel does not meet the limits set for proper lubricity properties. As part of the investigation fuel was obtained from the point where the vehicle allegedly filled its tank, 200km before the failure. This fuel was tested and the results can be seen on graph 7 in the annexure. This fuel clearly passes the test indicating that the driver most probably added kerosene at a lower price to put the extra money in his pocket.

5.4 During the investigation of another engine failure, it was established that when the customer ordered bulk supplies of diesel fuel, the fuel that was delivered to him was mixed with petrol. The petrol contamination in some cases were as high as 25%. Several of the engines of this contractor failed, amongst others a small 4 cylinder Japanese diesel vehicle. This particular vehicle was only in service for about 2 000km since a complete engine rebuilt. When the failed engine was stripped, it was found that scuffing of the piston crowns had occurred and that the pistons started seizing in the cylinder liner. The injectors were carefully removed and tested. The spray pattern obtained is shown in figure 3. When the injector needles were removed, it was found that the tips of the needles were badly discoloured and when the needles were investigated under the microscope it was found that the shank of the needles were scuffed as indicated in figure 6. These injectors were replaced as new and genuine when the engine was rebuilt. The fuel was then taken and tested on the SRV machine and the results are shown in graph 8 in the annexure. As can be seen the fuel failed the tests long before the minimum load carrying capacity was reached.

Several similar cases were investigated with results comparable to the above.

5.5 After receiving several complaints about engines failing, when used on fuel from a particular independent distributor, samples were obtained from this distributor. This distributor alleges that he was supplying coastal diesel, although his operation was in the North West Province of this country. The results of this alleged coastal diesel is shown in graph 9 in the annexure. This fuel was tested against the normal SABS 342 specification and complied with this specification. The viscosity was however at the bottom limit of the allowable viscosity. As can be seen this fuel did not pass the test and it is considered that this distributor is blending in kerosene with coastal diesel in such a way that it still satisfies the normal SABS 342 specification, but the fuel has very poor lubricating properties causing engine failures.

5.6 As another comparison, fuel was bought at a filling station in Durban and the results of this test are shown in graph 10 in the annexure. It can be seen that this fuel passes the test with flying colours.

Fuel was bought from a filling station in the Kempton Park area, and was tested on the SRV machine giving the result as shown in graph 11 in the annexure. As can be seen in the graph this fuel does not satisfy the requirements of this test and vehicles making use of this fuel are therefore under a threat of failure.

Finally a sample of diesel from Belgium was obtained and tested and the results of this fuel are shown in graph 12 in the annexure. The fuel passes the test with flying colours, but it is important to note that the friction co-efficient line lies even lower than the reference line of South African coastal refined diesel.

## 6. Conclusions

6.1 In the normal HFRR tests, a wear scar is measured and from this a number is obtained giving an indication of the lubricity of a fuel. The SRV machine gives a direct reading of friction coefficient from which lubricity can be determined. Tests are presently being carried out to correlate the result of the HFRR and the SRV machine.

6.2 The investigations clearly indicate that there is a direct relationship between poor lubricity of diesel fuels and engine failures, relating sticking of needles and the subsequent seizing of the piston.

6.3 In the view of the above, it is clear that there is a definite need for the inclusion of a specification on lubricity in the fuel specification SABS 342. The specification can hinge around the normal HFRR or the SRV machine, as both these machines give results from a small quantity of fuel in a short period of time. The Bosch test, although very precise, takes a 1000 hours to complete and is very costly. It also requires a reasonably large quantity of fuel.

7. Annexure

**Engen ADO Coastal Diesel**

**Ultimate Load Test:** Run at 110 degrees C, frequency 50 Hz, stroke length 1mm with 50 N increments of 1 min duration each.  
Break-through coefficient set at 0.3

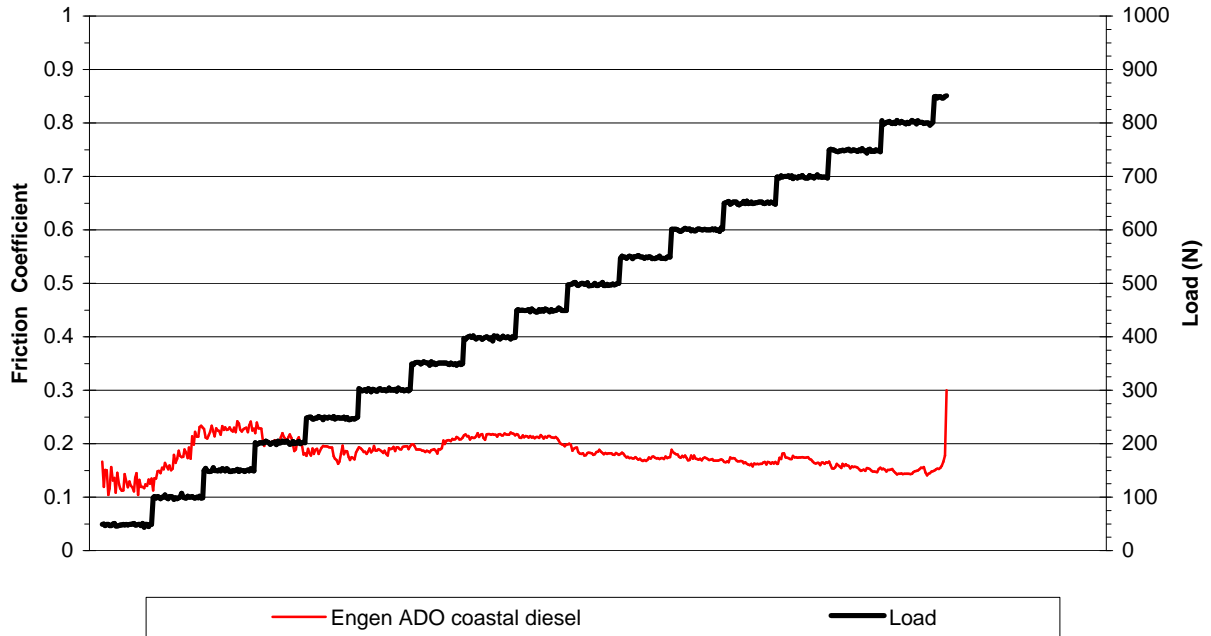

Graph 1

**Illuminating Kerosene**

**Ultimate Load Test:** Run at 110 degrees C, frequency 50 Hz, stroke length 1mm with 50 N increments of 1 min duration each.  
Break-through coefficient set at 0.3

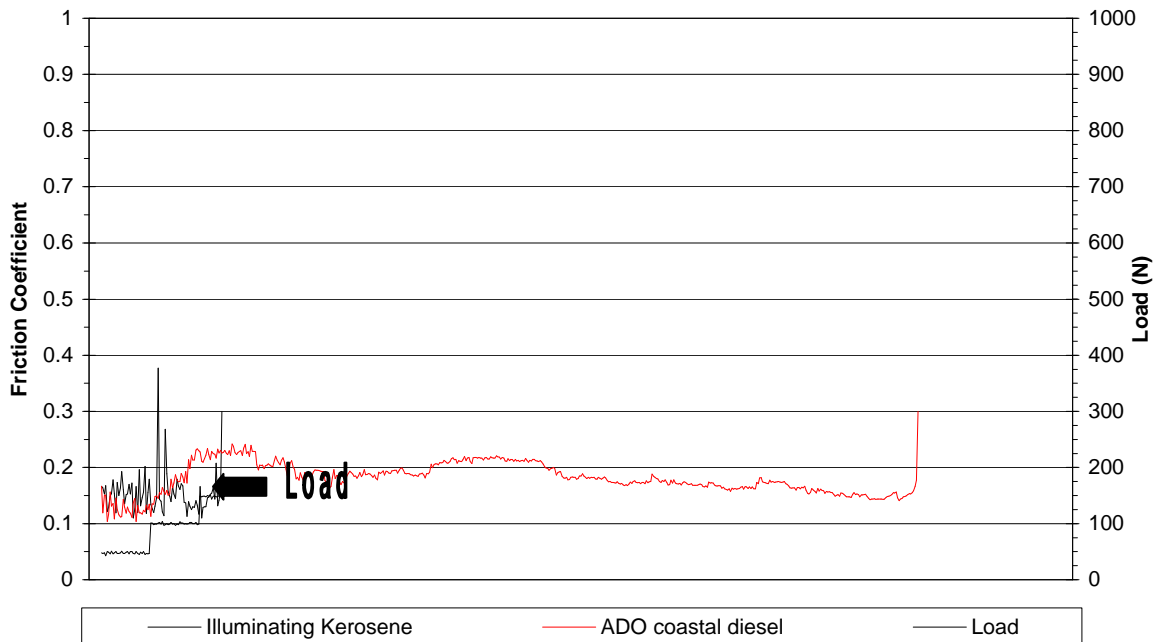

Graph 2

### Jet A1 (Aviation Kerosene)

Ultimate Load Test: Run at 110 degrees C, frequency 50 Hz, stroke length 1mm  
with 50 N increments of 1 min duration each.  
Break-through coefficient set at 0.3

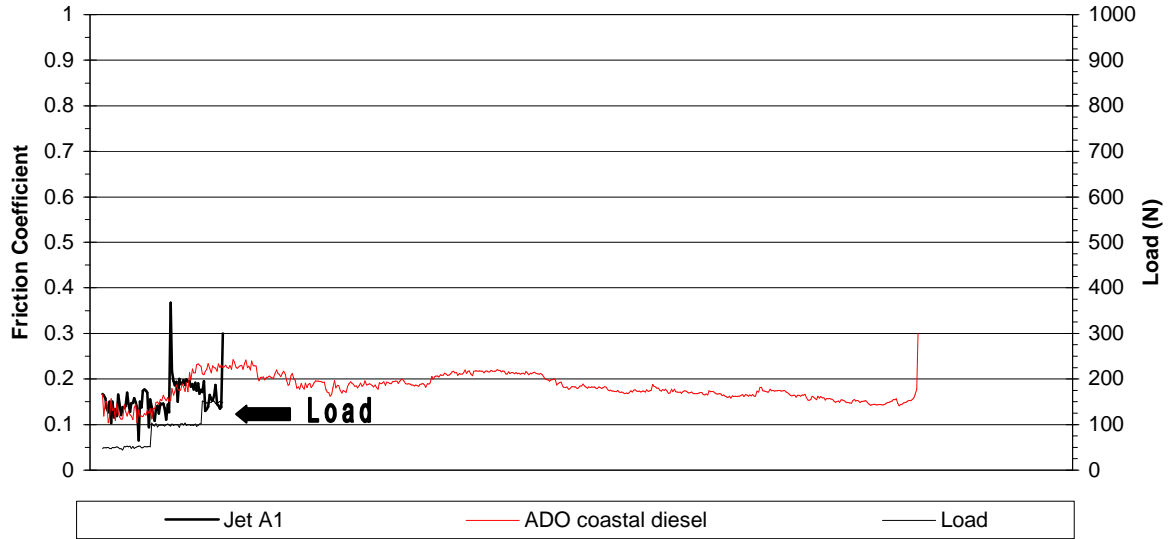

Graph 3

### Underground Diesel

Ultimate Load Test: Run at 110 degrees C, frequency 50 Hz, stroke length 1mm  
with 50 N increments of 1 min duration each.  
Break-through coefficient set at 0.3

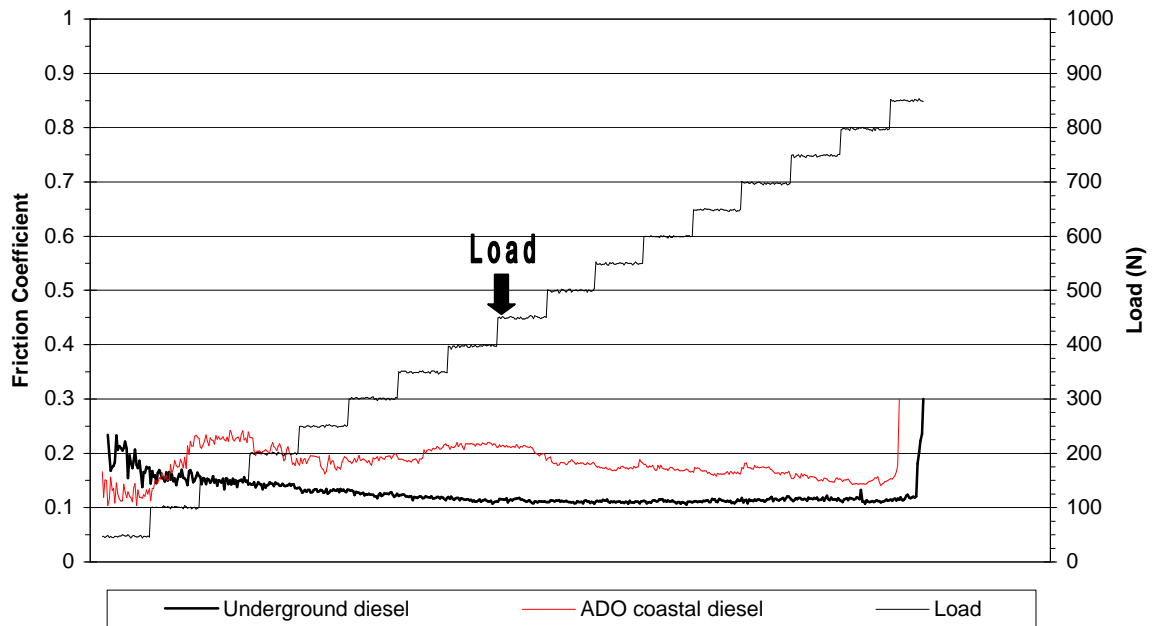

Graph 4

### Underground Diesel

**Injector Simulation Test:** Run at 110 degrees C, frequency 50 Hz, stroke length of 1 mm with 10 N increments of 30 sec duration each.

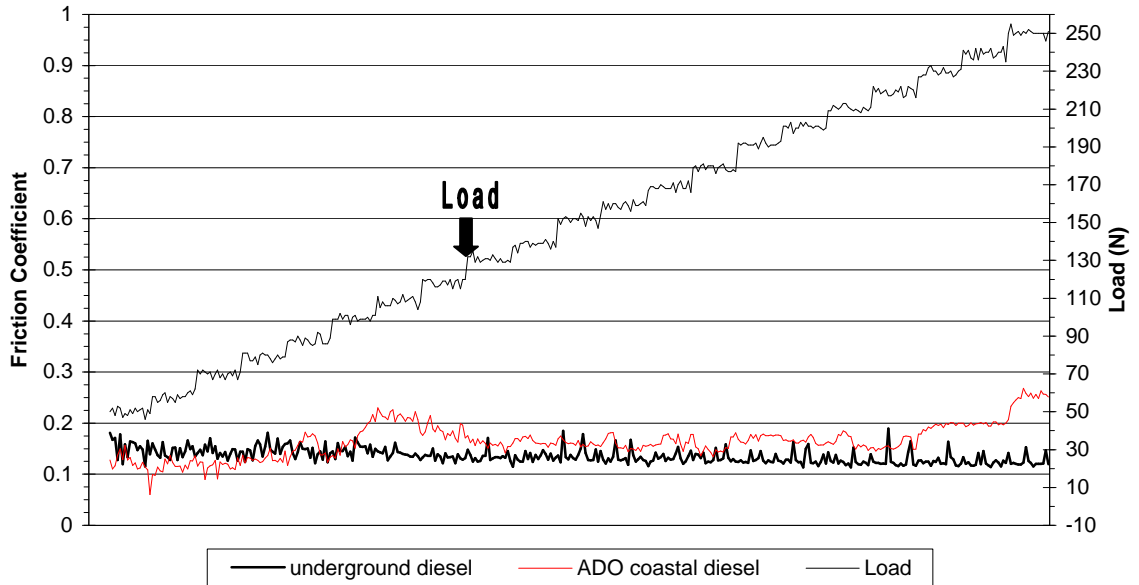

Graph 5

### Diesel from Vehicle Fuel Tank

**Ultimate Load Test:** Run at 110 degrees C, frequency 50 Hz, stroke length 1mm with 50 N increments of 1 min duration each. Break-through coefficient set at 0.3

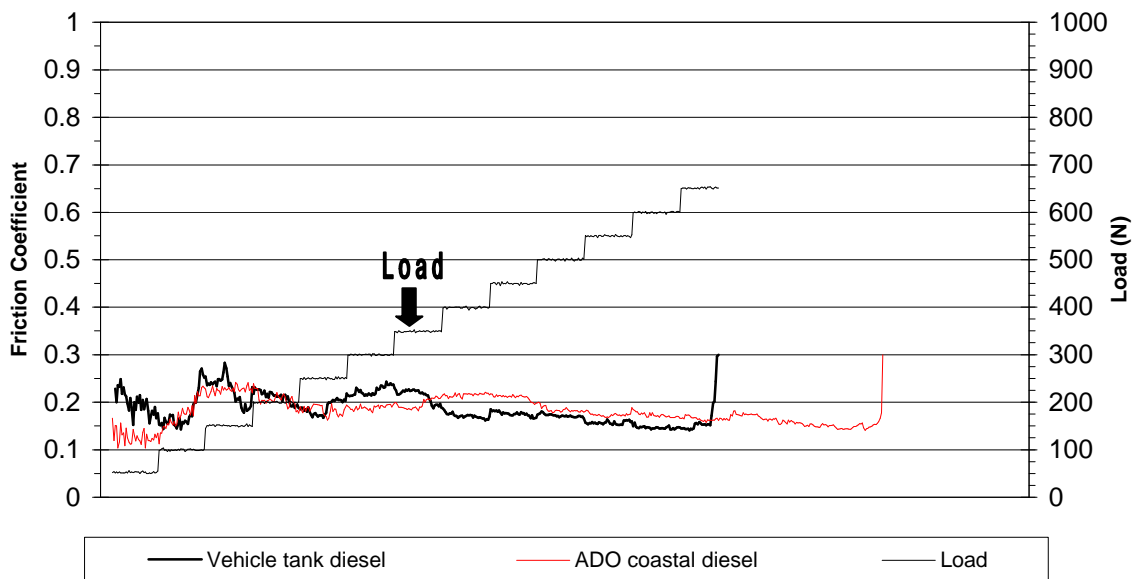

Graph 6

### Diesel from Vehicle Filling Point

Ultimate Load Test: Run at 110 degrees C, frequency 50 Hz, stroke length 1mm  
with 50 N increments of 1 min duration each.  
Break-through coefficient set at 0.3

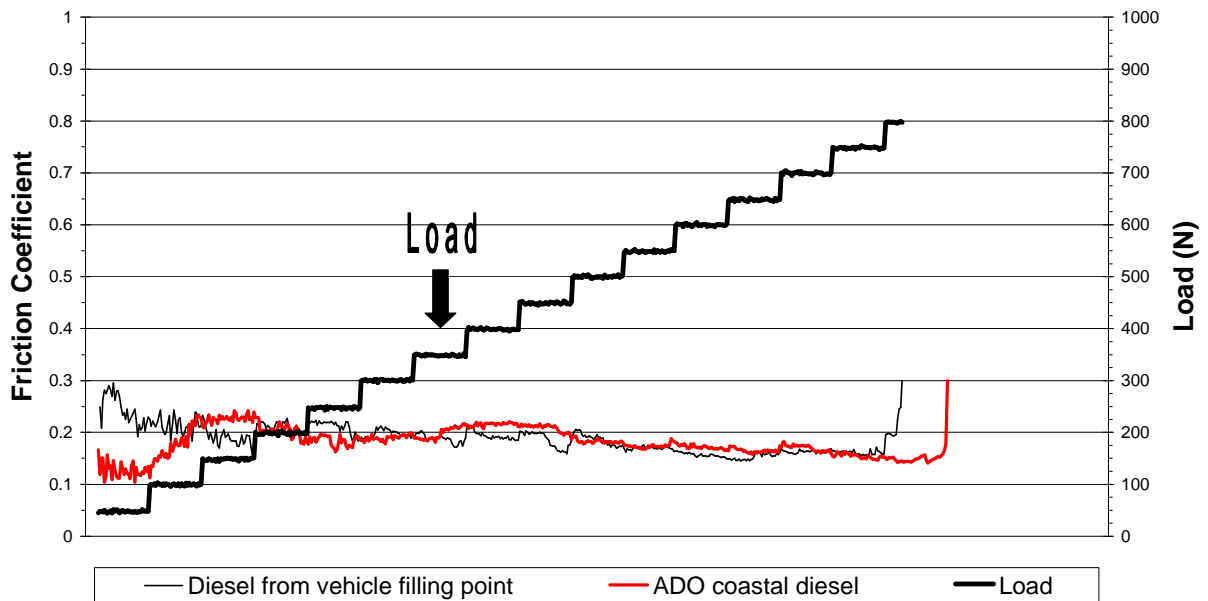

Graph 7

### Petrol and Diesel Mixture

Ultimate Load Test: Run at 110 degrees C, frequency 50 Hz, stroke length 1mm  
with 50 N increments of 1 min duration each.  
Break-through coefficient set at 0.3

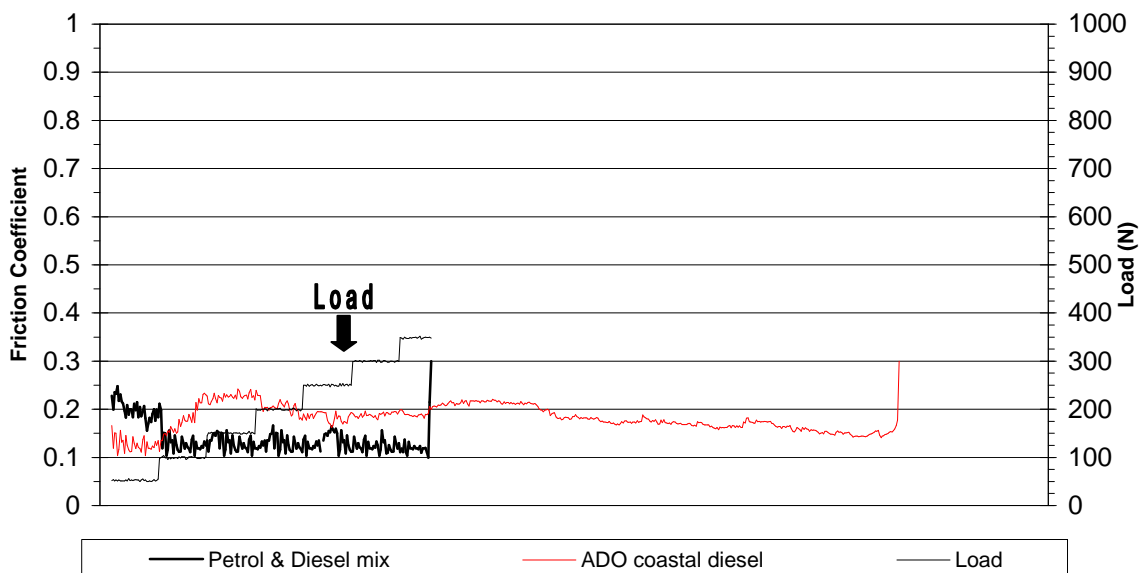

Graph 8

### Alleged Coastal Diesel Sample from an Independent Source

Ultimate Load Test: Run at 110 degrees C, frequency 50 Hz, stroke length 1mm  
with 50 N increments of 1 min duration each.  
Break-through coefficient set at 0.3

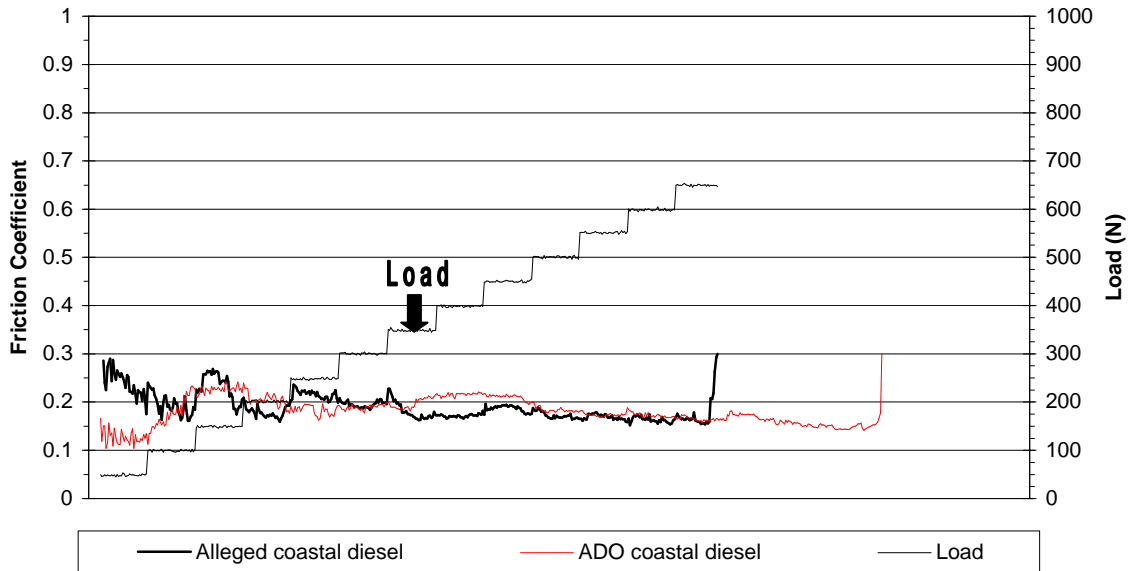

Chart 9

### Coastal Diesel from a Durban Filling Station

Ultimate Load Test: Run at 110 degrees C, frequency 50 Hz, stroke length 1mm  
with 50 N increments of 1 min duration each.  
Break-through coefficient set at 0.3

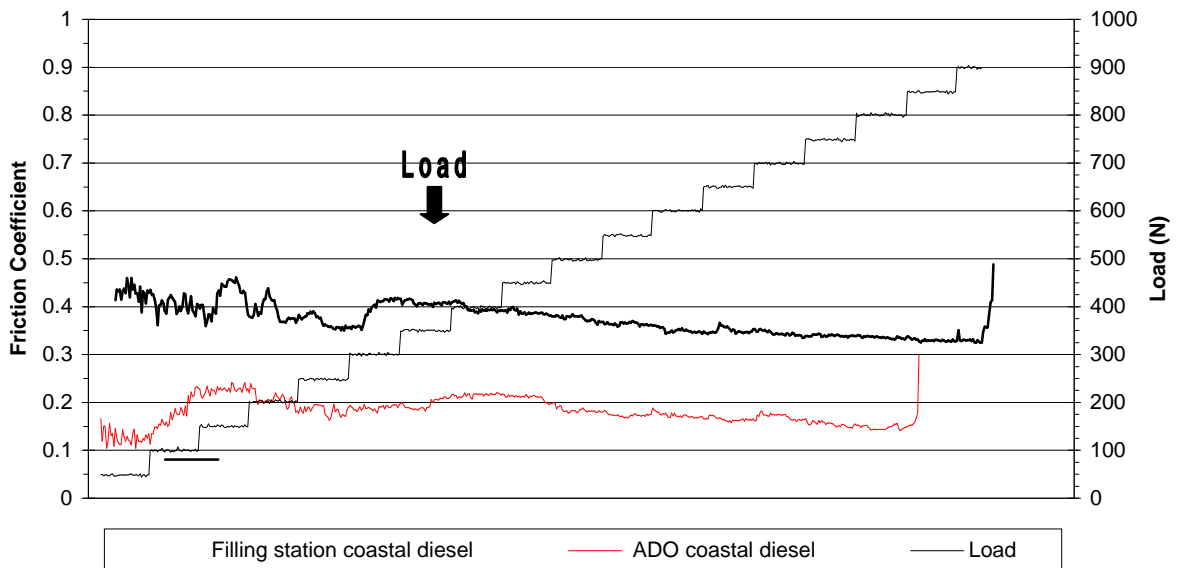
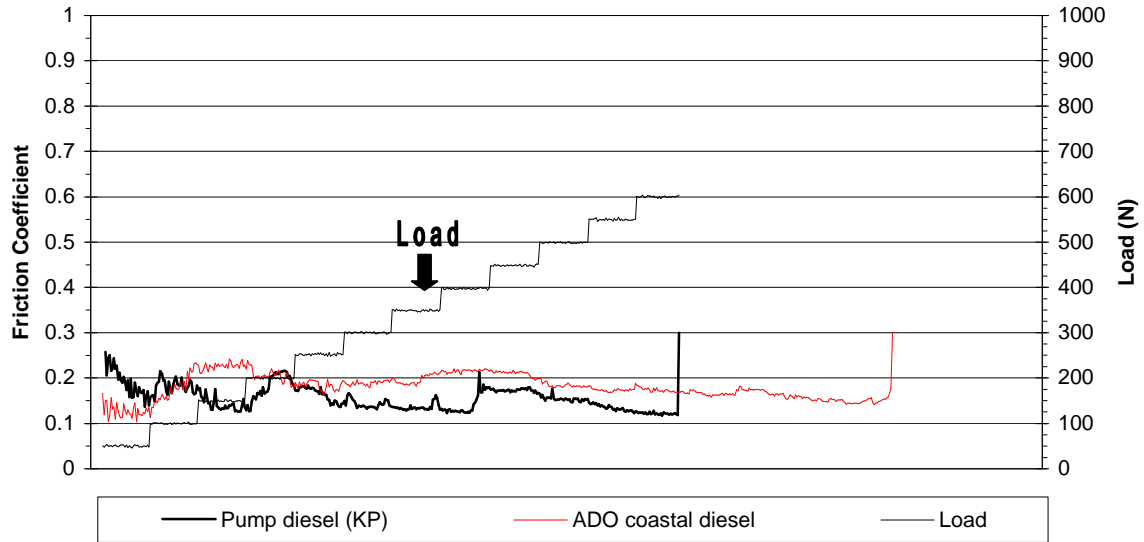

Chart 10

### Pump Diesel (Kempton Park)

**Ultimate Load Test:** Run at 110 degrees C, frequency 50 Hz, stroke length 1mm  
with 50 N increments of 1 min duration each.  
Break-through coefficient set at 0.3



Graph 11

### European Diesel

**Ultimate Load Test:** Run at 110 degrees C, frequency 50 Hz, stroke length 1mm  
with 50 N increments of 1 min duration each.  
Break-through coefficient set at 0.3

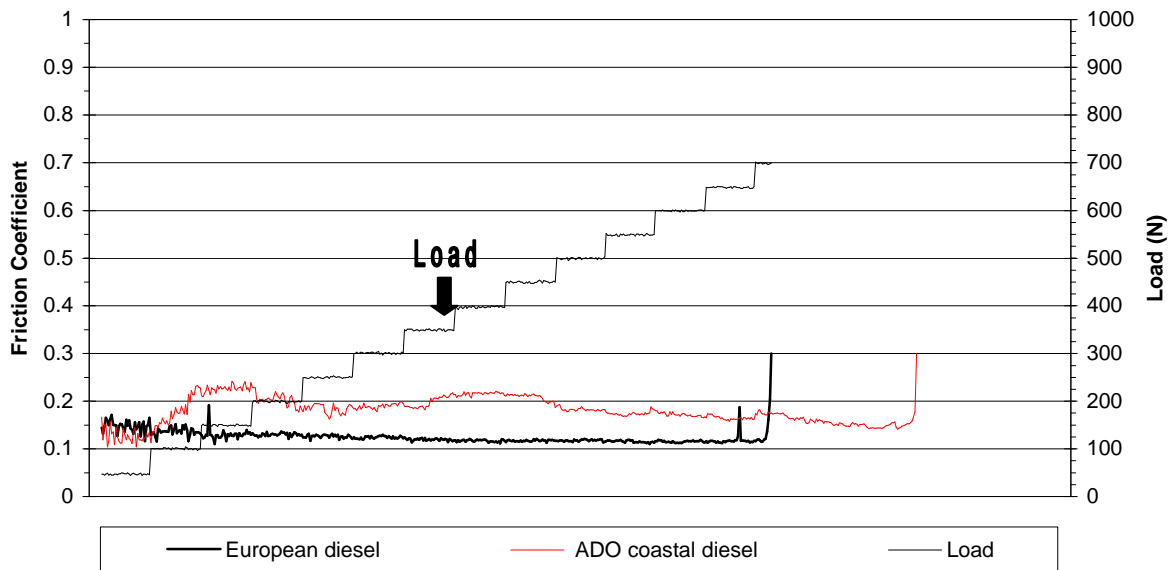

Graph 12